

STRAIGHT 2 HOLE FLANGE FLOATING JACK

R128.263.711

CRIMP TYPE - CABLE 2.6/50 S

Series : **BMA**

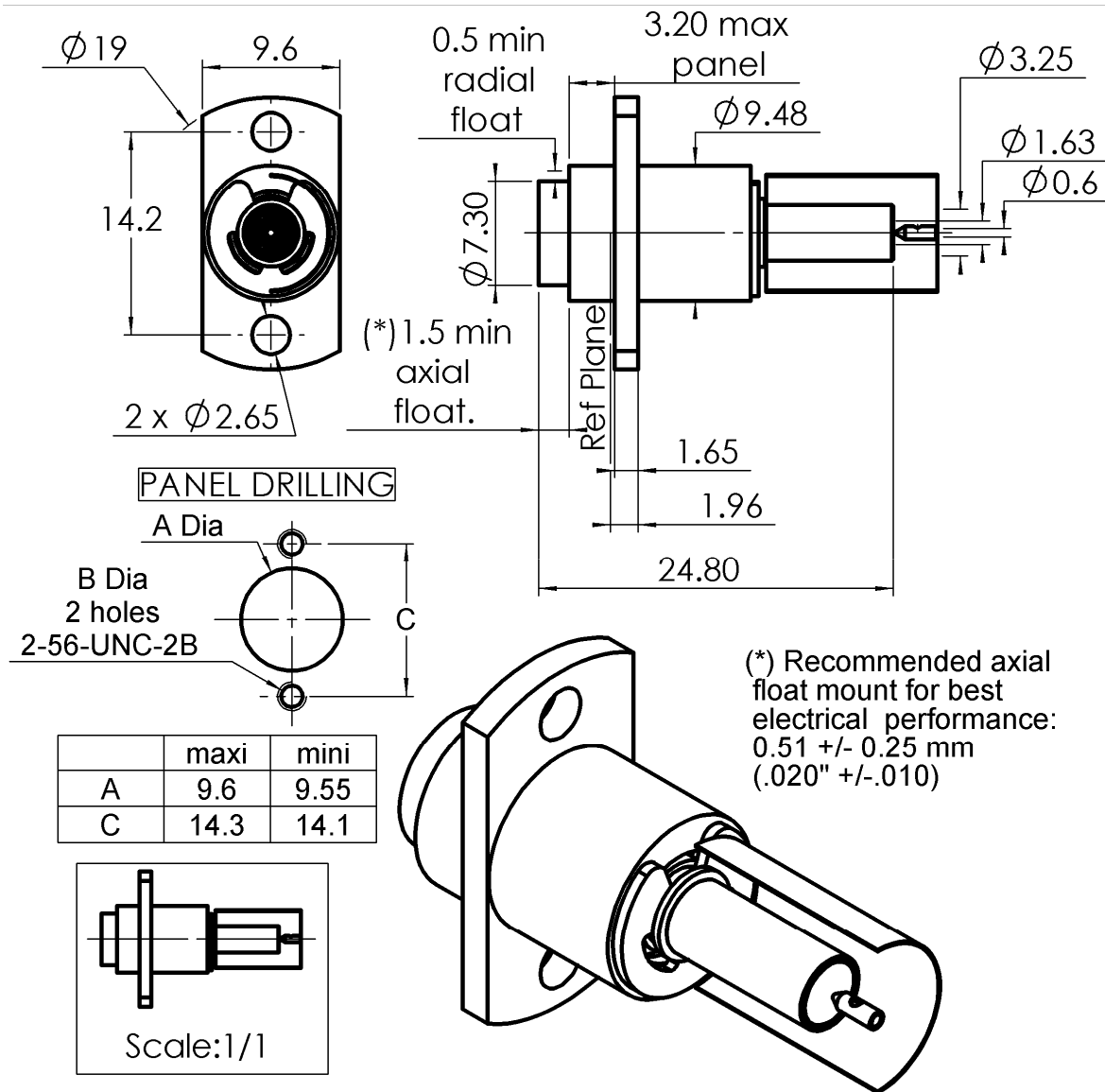

All dimensions are in mm.

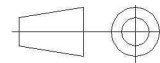

COMPONENTS	MATERIALS	PLATING (μm)
BODY	STAINLESS STEEL	PASSIVATION
CENTER CONTACT	BERYLLIUM COPPER	GOLD 1.3 OVER NICKEL2
OUTER CONTACT	BERYLLIUM COPPER	NPGR
INSULATOR	PTFE	
GASKET	-	
OTHERS PARTS	BRASS	NICKEL 2
-	-	-
-	-	-

Issue : 0940 B

In the effort to improve our products, we reserve the right to make changes judged to be necessary.



STRAIGHT 2 HOLE FLANGE FLOATING JACK

R128.263.711

CRIMP TYPE - CABLE 2.6/50 S

Series : **BMA**

PACKAGING

Standard	Unit	Other
100	'W' option	Contact us

SPECIFICATION

ELECTRICAL CHARACTERISTICS

Impedance		50 Ω
Frequency		0-12.4 GHz
VSWR	1.15 +	0,0200 x F(GHz) Maxi
Insertion loss		0.03 √F(GHz) dB Maxi
RF leakage	- (50 - F(GHz)) dB Maxi
Voltage rating		250 Veff Maxi
Dielectric withstanding voltage		750 Veff mini
Insulation resistance		5000 MΩ mini

CABLE ASSEMBLY

Stripping	a	b	c	d	e	f
mm	1,50	6,50	11,1	0,00	9,60	0,00

Assembly instruction : **Crimp 01**

Recommended cable(s)

RG 188

RG 316

KX 22A

Characteristics indicated on this data sheet are those that can be achieved with the highest performance cable. Intrinsic limitations of the cable may diminish the performance of the assembly

Cable retention

- pull off **110** N mini
- torque **NA** N.cm

MECHANICAL CHARACTERISTICS

Center contact retention		
Axial force – Mating end	27	N mini
Axial force – Opposite end	27	N mini
Torque	NA	N.cm mini

TOOLING

Part Number	Description	Hexagon
.	.	.
R282.211.000	CRIMPING TOOL	3.25
R282.235.003	CRIMPING DIES M22520/5-03	3.25
R282.293.000	CRIMPING TOOL M22520/5-01	

Recommended torque		
Mating	NA	N.cm
Panel nut	NA	N.cm
Clamp nut	NA	N.cm
A/F clamp nut	0,0000	mm

Mating life	1000	Cycles mini
Weight	4,7900	g

OTHER CHARACTERISTICS

ENVIRONMENTAL

Operating temperature	-55/+125	°C
Hermetic seal	NA	Atm.cm3/s
Panel leakage	NA	

Issue : **0940 B**

In the effort to improve our products, we reserve the right to make changes judged to be necessary.

